

Ryan Model 904 Rotary Table Utility Slicer with In-feed Conveyor

High-speed versatile horizontal slicer for bagels, English muffins, buns, croissants, etc.

Capacity: Up to 8000 units per hour depending on product and in-feed method.
Will handle product up to 7 ½" in width, 3" tall, and 12" long.

Single-blade (904A) or Dual-blade (904B) Configuration

Standard Features:

- 3 foot diameter rotary table
- 7" main conveyor and 24" wide in-feed conveyor
- 23" space between table and upper conveyor capture
- USDA approved powder-coated tubular steel frame
- Plated steel blade housings, conveyors, and guards
- 1 HP motors on blades with brakes to stop blades within one revolution upon shut-down
- Coded magnetic safety switches on Lexan blade covers that allow operation only when covers are in place
- 12" circular saw blades
- Adjustable for cut height, depth, and product width
- Turn table & conveyor variable speed drives
- 3-Phase power (208 or 240 volt) 20 amp
- 5" casters

Options:

- Teflon-coating on blades
- In-table in-feed product guide (for sub-roll-type products)
- Right-hand or left-hand configuration (right-hand shown)

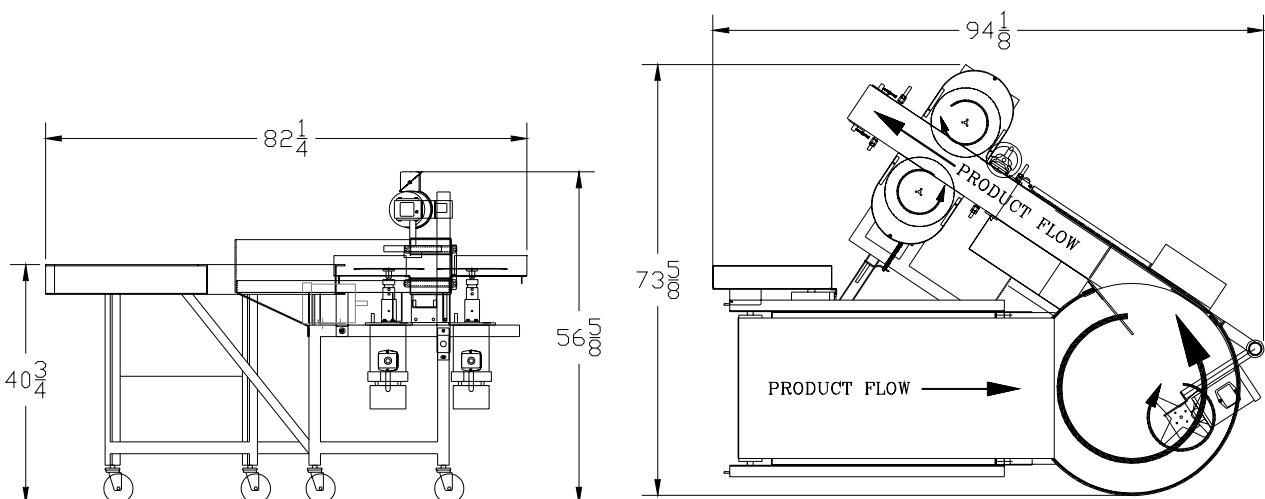

RYAN
TECHNOLOGY, INC.