

Ryan Model 8903 Dual Use In-Line Center- & Side-Hinge Slicer

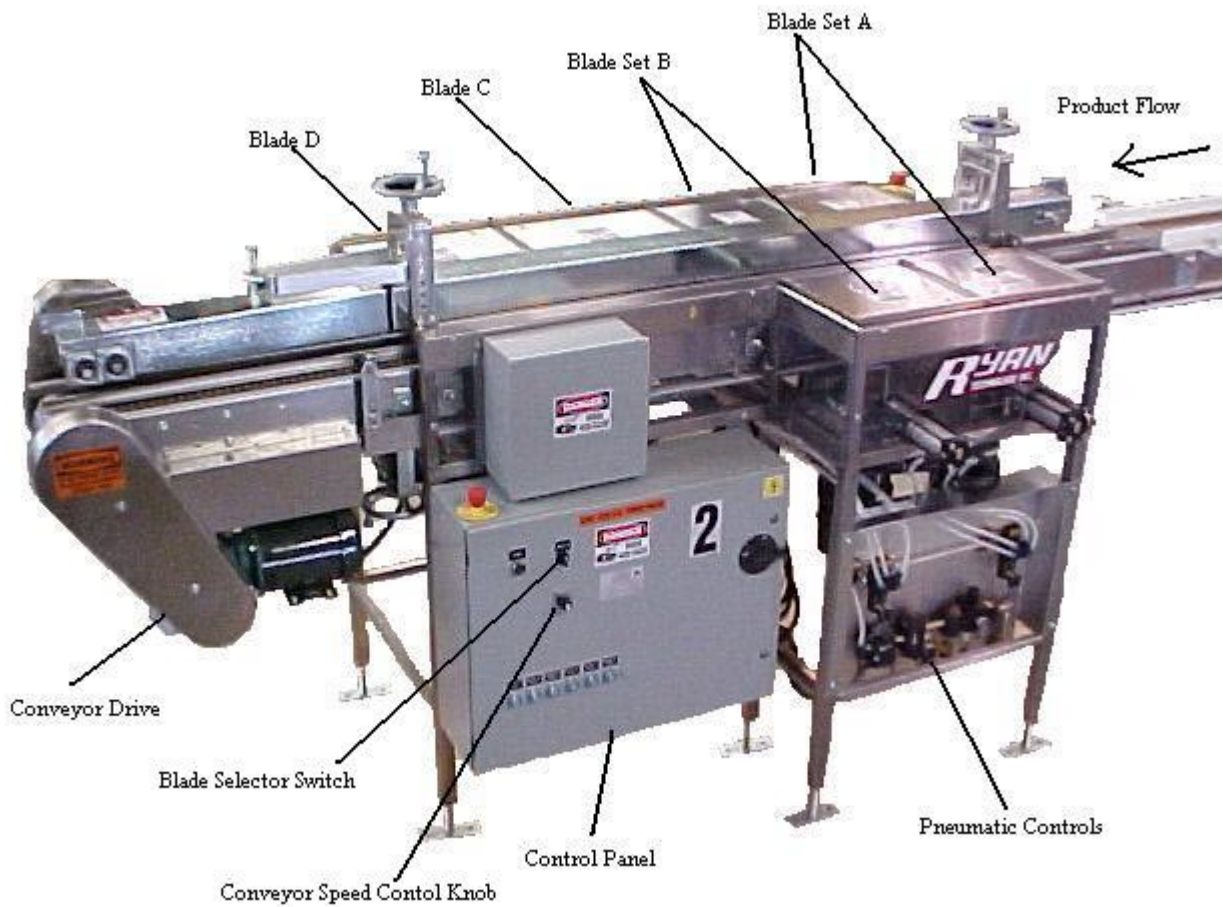

RYAN
TECHNOLOGY, INC.

Ryan Model 8903 Dual Use In-Line Center- & Side-Hinge Slicer

High-speed single-line horizontal slicer for sub-rolls, bagels, English muffins, buns, croissants, etc.

Capacity: Up to 400 units per minute.
Will handle product up to 6" in width and 3" tall.

Standard Features:

- 6" wide conveyor with KVP plastic chain
- Adjustable upper conveyor to slow product after blades
- USDA approved powder-coated tubular steel frame
- 1 HP motors on blades with brakes to stop blades within one revolution upon shut-down
- Coded magnetic safety switches on blade access doors that allow operation only when door is closed
- Four 12" and two 14" Teflon-coated circular saw blades
- Air-operated blade change system (60 lb. + air supply needed)
- Air pressure regulator and oiler on board
- Adjustable for cut height, depth, and product width
- Factory adjustable conveyor speed
- 3-Phase power (208, 240, 480 volt) 20 amp
- Adjustable conveyor bed height via screw-in-type feet

Options:

- Conveyor bed adjustable height for blade cut, adds 6" to conveyor length (independent of feet)
- PLC conveyor variable speed drive
- Product counter

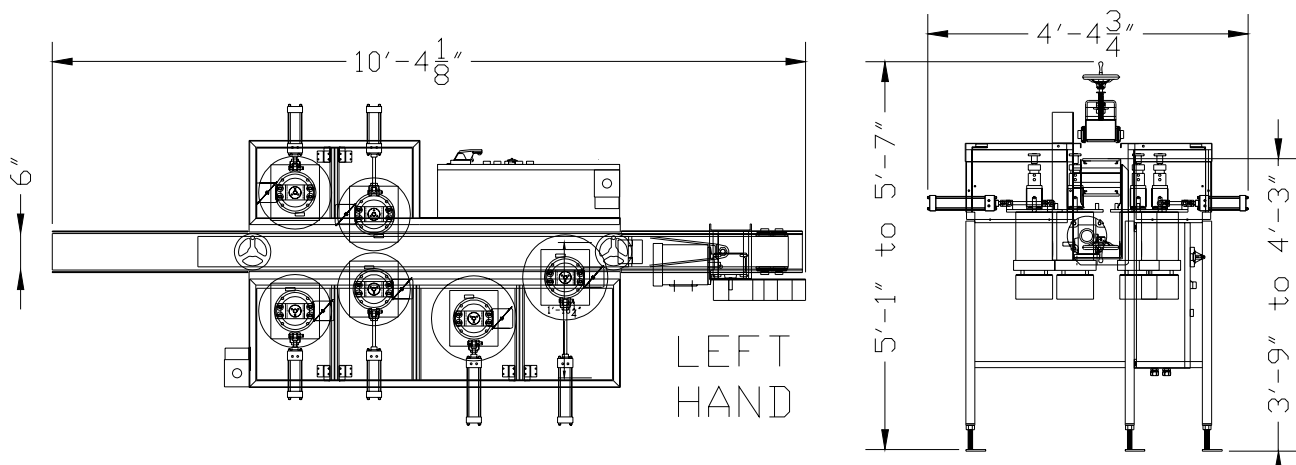

RYAN
TECHNOLOGY, INC.