

Ryan Model 797 Rotary Table In-Feed Unit

Rotary table unit to direct product into a single-line.

Capacity: Up to 8000 units per hour depending on product and in-feed method.
Will handle product up to 6" in width, 3" tall, and 24" long.

Standard Features:

- 4 foot diameter rotary table
- 6" wide conveyor with KVP plastic chain
- USDA approved powder-coated tubular steel frame
- Plated steel housings, conveyors, and guards
- Factory adjustable conveyor speed (non-vary-drive machines)
- 3-Phase power (208 or 240 volt) 20 amp
- 5" casters or adjustable rigid feet

Options:

- Turn table/conveyor variable speed drive
- Product counter
- Product spacing wheel
- In-feed conveyor up to 40" wide, level or inclined
- In-table in-feed product guide (for sub-roll-type products)
- Right-hand or left-hand configuration (left-hand shown)

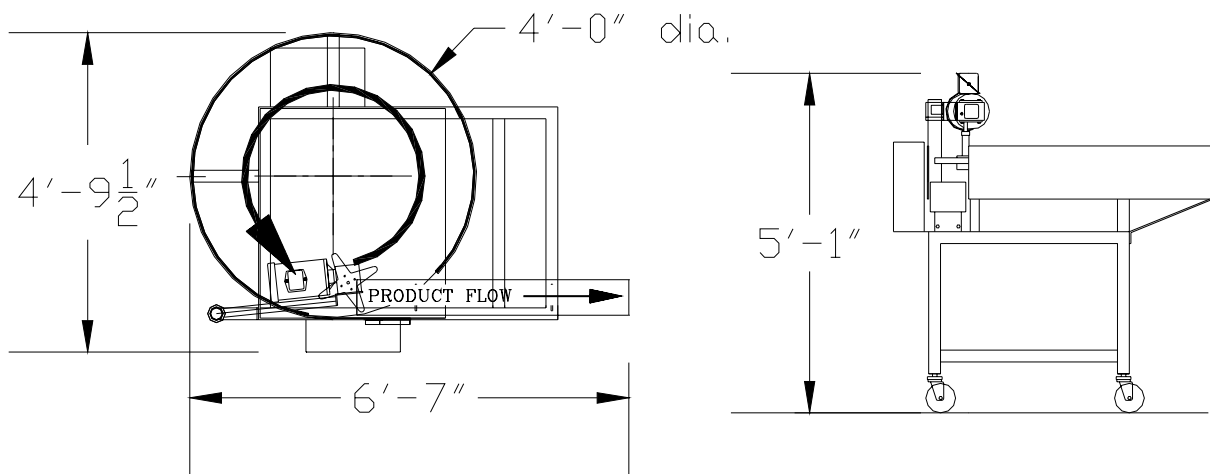

RYAN
TECHNOLOGY, INC.